

DSP-A

Light indicator showing on an electronic screen the status of the doors of the ambulance

OPEN DOORS MONITOR

For security reasons, it is important to know if the ambulance's doors are closed.

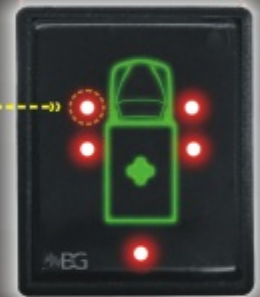

The ambulance silhouette with its corresponding doors appears on the screen; the corresponding indicator flashes while the door is opened.

Small size, easy to install on a visible place of the cabin.

The ambulance silhouette remains on for one minute while there is an open door in order to avoid visual disturbance, but the indicator will remain on continuously.

If all the door are closed, the electronic screen remains off.



Control Unit

Electronic Screen

Electronic equipment that shows the doors' status in the ambulance.

DSP-A

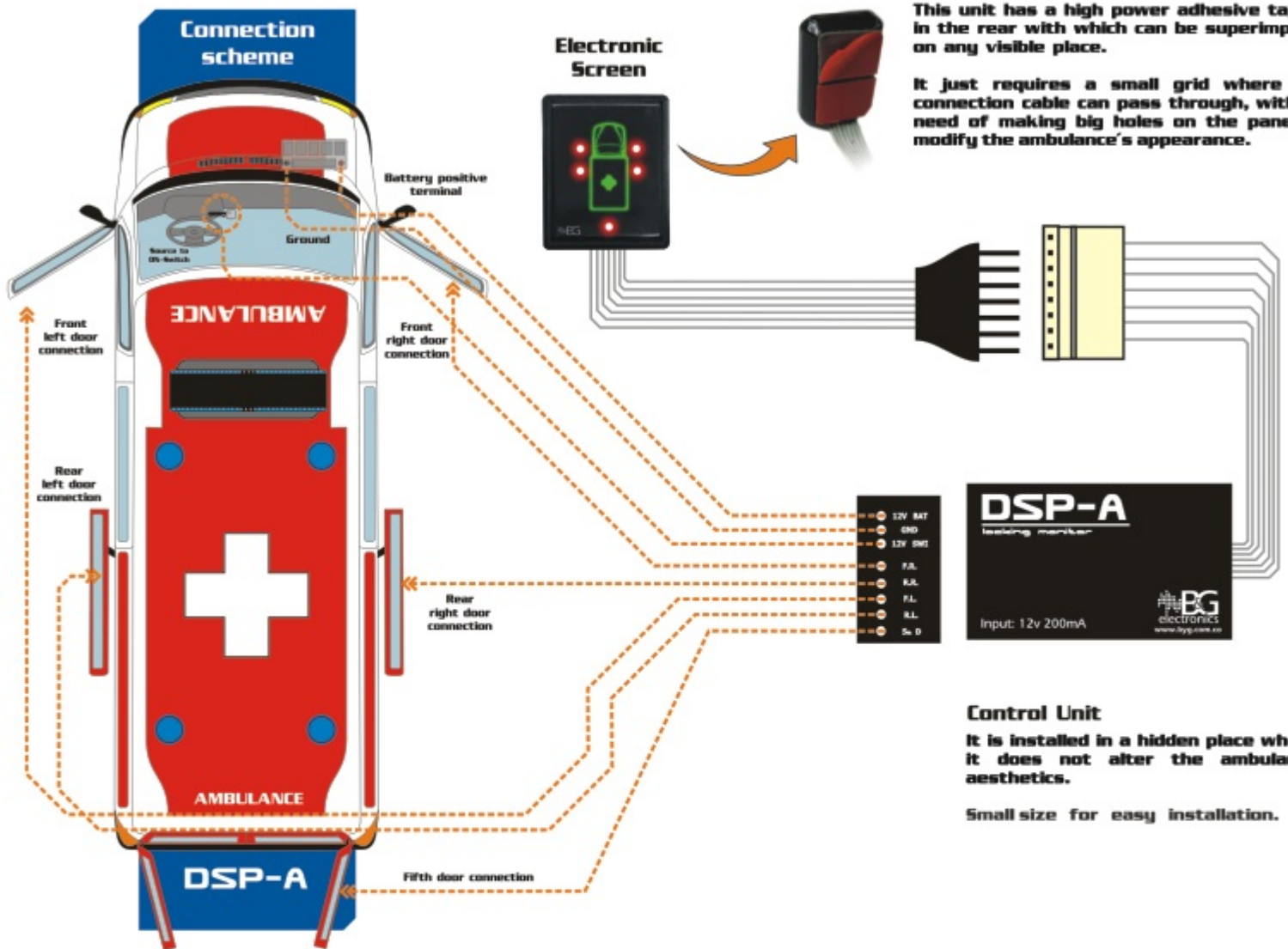

This unit has a high power adhesive tape in the rear with which can be superimpose on any visible place.

It just requires a small grid where the connection cable can pass through, with no need of making big holes in the panel or modify the ambulance's appearance.



Control Unit

It is installed in a hidden place where it does not alter the ambulance aesthetics.

Small size for easy installation.

Models

All DSP models are available from 2 to 5 ambulance's doors

DSP-A 03



3 Doors

DSP-A 04



4 Doors

DSP-A 05



5 Doors

